

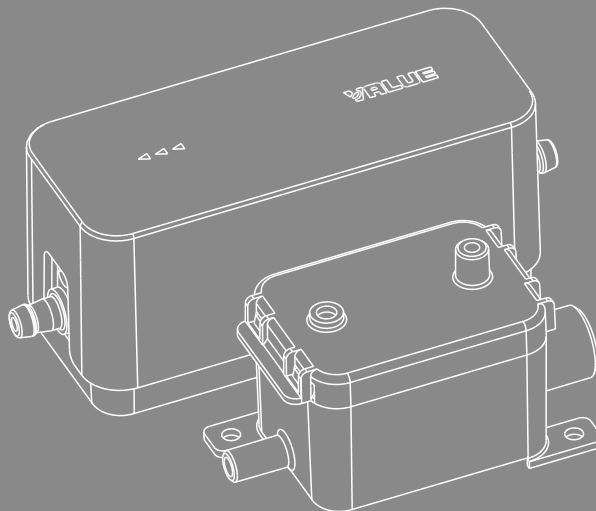

# Mini Condensate Pump User Manual



**VALUE**

VALUE Mechanical & Electrical Products CO., LTD

Addr: No. 5, 3rd Street, East Industrial Park, Wenling, Zhejiang, China

Tel: +86-576-86191959

Email: [value@worldvalue.cn](mailto:value@worldvalue.cn)    [www.worldvalue.cn](http://www.worldvalue.cn)

VALUE • Quality Assurance

## CONTENTS

Structure .....	1
Accessories .....	1
Dimensional Drawing .....	2
Technical Parameters .....	2
Flow Rate .....	3
Operation Note .....	3
Installation Steps .....	4
Common Troubleshooting .....	9
Scope of Warranty .....	9

## I. Structure

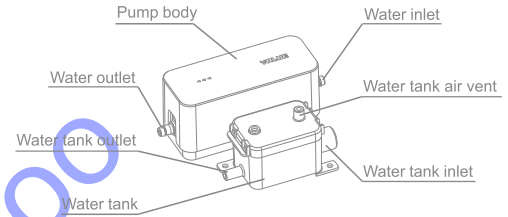

## II. Accessories

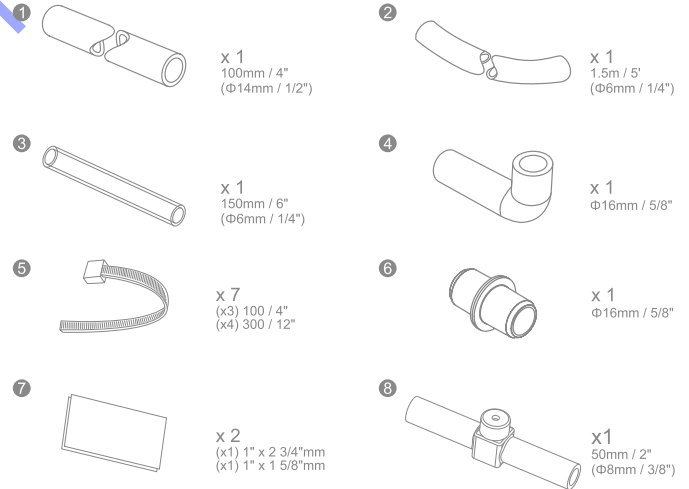

## Condensate Pump

VALUE

9



x 2  
20 x 20mm / 3/4" x 3/4"

10



x 1  
25mm to 16mm  
(1" to 5/8")

### III. Dimensional Drawing (Unit:mm)

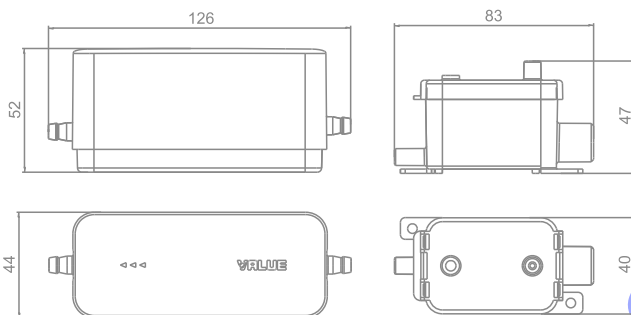

### IV. Technical Parameters

Model	S1	S2
Voltage	100-240V/50-60Hz	100-240V/50-60Hz
Discharge head (Max.)	10m / 33t	10m / 33t
Flow rate (Max.)	24L/h / 6.4 US GPH	40L/h / 10.6 US GPH
Effective water tank capacity	50ml	50ml
Unit output (Max.)	9kW / 30,000btu/h	13kW / 45,000btu/h
Noise at 1m	19dB(A)	21dB(A)
Applicable ambient temperature	0°C-50°C	0°C-50°C

## Condensate Pump

VALUE

### V. Flow Rate

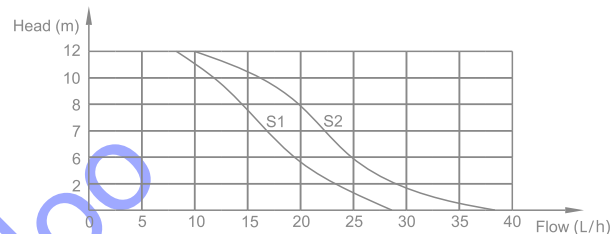

### VI. Operation Note

1. The condensate pump is only applicable to the condensate water of air conditioner units, but not applicable to any other corrosive liquids.
2. It can't be immersed in water and used as a submerged pump, otherwise it will be subject to electric shock.
3. Upon installation or adjustment, please ensure that the condensate pump is not connected to the power supply.
4. Installation and maintenance shall be operated by professionals, in order to avoid the occurrence of danger.
5. Please use the condensate pump in indoor environment, and do not use the equipment in the oil mist environment, especially in dusty environment.
6. Proper use and maintenance can prolong the service life of the product. It is recommended to check and clean the draining pump of the air conditioner before changing seasons and using it in the next year.
7. Please install an independent power source line to ensure continuous power supply.
8. Please select a condensate pump with appropriate pumping speed in accordance with the air-conditioner's refrigerating capacity, otherwise water overflow may be caused by failure of timely water discharge by the condensate pump due to excessive water inflow in a short time, besides, frequent startup and continuous operation of the motor may also lead to overheat and fault.
9. A relay is embedded inside the condensate pump, which will actuate and cut off the power supply to the air conditioner unit once the warning water level is exceeded, in which case please promptly shut down the air conditioner unit, take pictures and ask professionals for overhaul.

VII. Installation Steps

1. Connect the vent tube to the air vent of the water tank (accessory ③).
2. Connect the water outlet of the water tank with the connection pipe (accessory ②), Wrap the connection joint with a cable tie(accessory ⑤).

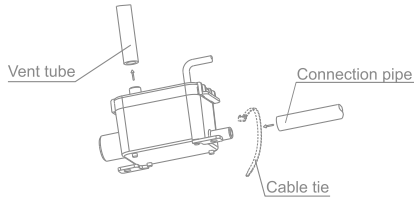

3. Connect the water inlet of the water tank with the outlet pipe of the air conditioner.

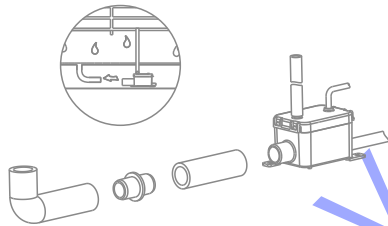

4. The water tank shall be placed horizontally, and with its bottom provided with mounting holes for bolt fastening or pasted with nylon buckles(accessory ⑦), to reduce abnormal noise due to vibration.

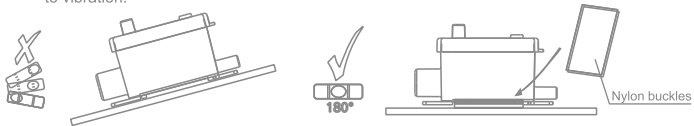

5. Secure the pump body properly by putting nylon buckles(accessory ⑦) onto the bottom of the pump firmly and reliably, to reduce abnormal noise arising from vibration.

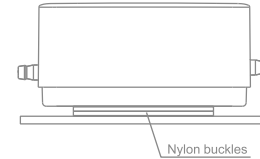

6. For the layout of the pump, please refer to the following diagram.

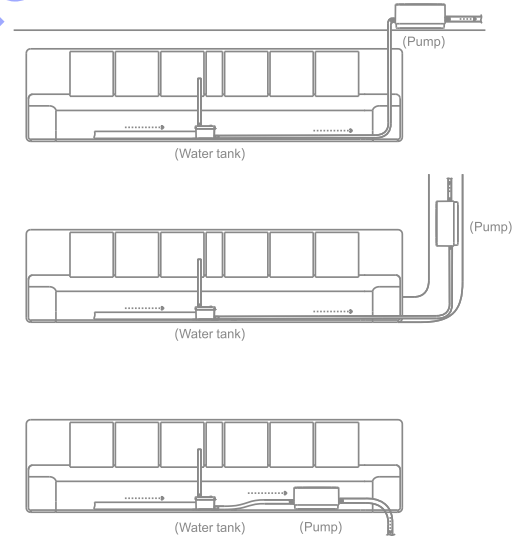

7. Signal lines and water pipes between the water tank and the pump body are connected.  
Attention shall be paid to connect the connection pipe(accessory ②) to the water inlet end of the pump body by fixing it with cable tie(accessory ⑤). The connection pipe can be fixed with wire clamp (accessory ⑨).

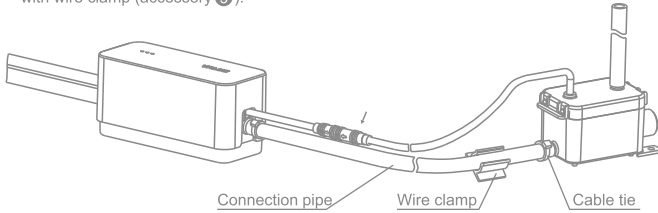

8. The water outlet of the pump body is connected with the water outlet pipe. The outside pipe is  $\Phi 6\text{mm} \times \Phi 9\text{mm}$  (inner diameter x outer diameter). The water pipe joint is fixed with self-locking nylon drawstring. Please note that the water pipe cannot be bent or blocked.

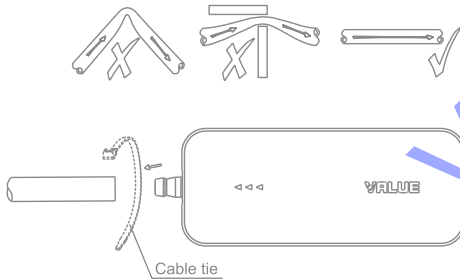

9. The height drop between the bottom of the water pipe and the pump body exceeding 1m is prone to cause siphon effect. Anti-siphon tube assembly (accessory ⑧) can be connected to prevent siphon effect. It should be noted that the fixed position of anti-siphon tube assembly should not be lower than the height of the pump body.

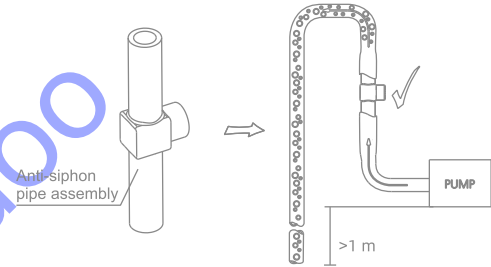

10. The power cable has 5 cores of wires, and the blue core and brown core are used for power supply and the purple core, yellow core and grey core are used as signal wires for the relay. Please correctly connect the power cable according to the schematic diagram.

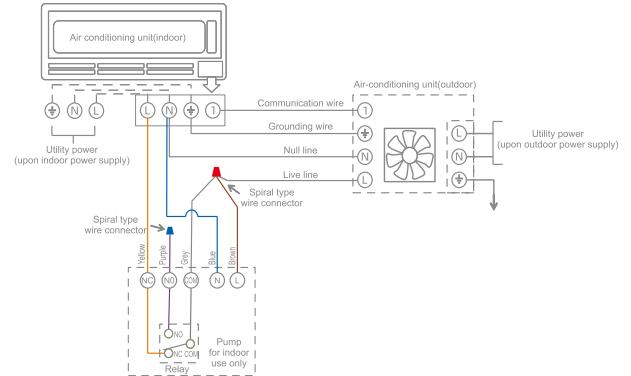

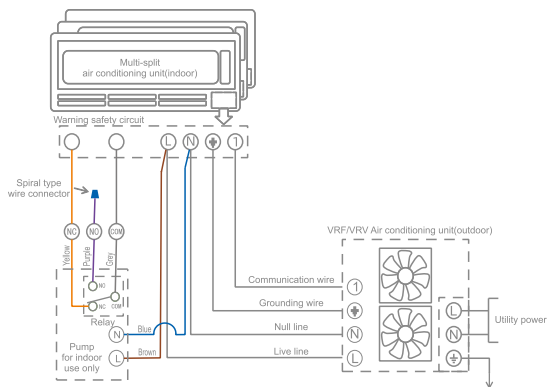

In respect of the terminals of the relay, terminal NO indicates normal open, terminal NC indicates normal close, and terminal COM represents a common terminal. Terminals NO or NC shall be connected, dependent on different air conditioner systems, and vacant terminals shall be shielded with spiral-type wire connectors. For an ordinary air conditioner system, terminal NC shall be connected to the air conditioner system.

11. Check that all water pipes and electric wires are connected correctly, and power on the air conditioner unit and the condensate pump.
12. Use a container with water to slowly fill the water into the air conditioner unit's evaporator tray, and observe whether the draining pump can operate normally and if any water leakage from the pipeline.
13. A relay is embedded in the condensate pump, and once the water level exceeds the limit water level due to insufficient water discharge, the relay will actuate to shut down the air conditioner unit, and recover the power supply if the water level becomes controlled within limits.
14. Following completion of the above test, if the condensate pump can function properly, then the installation is complete.

### VIII. Common Troubleshooting

Fault	Fault Causes	Fault Removal Method
The draining pump fails to be started normally	The power cord does not work.	Check whether the power cable is plugged and whether the power source is on
	The signal line is not connected properly.	Check that the signal lines are plugged properly.
	Electrode surface contamination	Regularly clear the water inlet cotton filter, water tank and water level electrode surface
	Tilted pump placement	Check and adjustment of water tank level through the mini-type horizontal column
Excessive operation noise of condensate pump	Siphonic effect leads to decrease of water volume in the pipeline, and air in the water in the preliminary stage of water pumping leads to excessive noise	Raise the height of the discharge pipe's outlet or the external anti-siphon elements
	The outlet pipe is squeezed or bent, leading to obstruction of water discharge	Check the discharge pipe layout
Water overflow	The outlet pipe is squeezed or bent, leading to obstruction of water discharge	Check the discharge pipe layout
	The water inlet's cotton filter is obstructed without clearance	Regularly clear foreign matters on the discharge outlet's cotton filter, and also clear the accumulated dust on the air-conditioner condenser

### IX. Scope of Warranty

The scope of warranty is as follows:

1. As verified by qualified detection institutions, the product is deemed to be defective;
2. The product is dismantled and repaired without authorization;
3. Provided that the product is used and operated correctly in accordance with the Operating Instructions, then all warranty services in relation to the product shall be available only in the warranty period.
4. The product's warranty period is one year.

#### Correct Disposal of this product:

This marking indicates that this product should not be disposed with other household wastes throughout the EU. To prevent possible harm to the environment or human health from uncontrolled waste disposal, please use the return and collection systems or contact the retailer where the product was purchased. They can take this product for environmental safe recycling.

